

**DC UPS FN**

12V/20A

24V/10A

24V/15A

-48V/5A

-48V/10A



# DC UPS FN

- Compact and easy to install
- 3-Stage Battery Charger
- Continuous power
- Fixing in rails of 19"

**1U**

# APPLICATION

The ALGcom DC UPS line is designed to protect your equipment against surges and faults, ensuring excellent performance and preventing your equipment from potential problems in the field.

## COMPACT AND EASY TO INSTALL

The ALGcom DC UPS Line was thought to meet 1U Design standards. Taking up little space, with possibility of installation in vertical and horizontal, the ALGcom DC UPS is performance and efficiency guarantee in telecom.

## BATTERIES CHARGER

Designed to work with lead acid batteries, the ALGcom Nobreak DC UPS feature a 3-stage charger, described below. An intelligent algorithm that runs on the DC UPS controls the charger.

**Stage 01-Constant Current:** Operates with constant current that can be programmed depending on the model, in 1A, 3A, 5A or 10A, allowing gradual and controlled charging of the batteries. When they reach full charge, the charger goes to the next stage.

**Stage 02-Equalization:** At this stage, the charger applies a constant voltage in order to equalize the voltage of each cell of the battery. In this way, the effect of premature sulfating of the plates is reduced, promoting an increase in the battery charge capacity and, consequently, its lifespan. Once equalization occurs, the charger switches to the next stage.

**Stage 03-Flutuation:** This is the final stage of the battery charging process, where a constant fluctuating voltage is applied in order to cancel out the self-discharge effect, allowing the battery to remain in its best state of charge for a long period.

**Nobreak Mode:** Responsible for powering the devices in the event of a light fall.

CHARGER CONFIGURATION				
MODEL	1A	3A	5A	10A
12V / 20A	x	x	x	x
24V / 10A	x	x	x	
24V / 15A	x	x	x	x
-48V / 5A	x	x	x	
-48V / 10A	x	x	x	

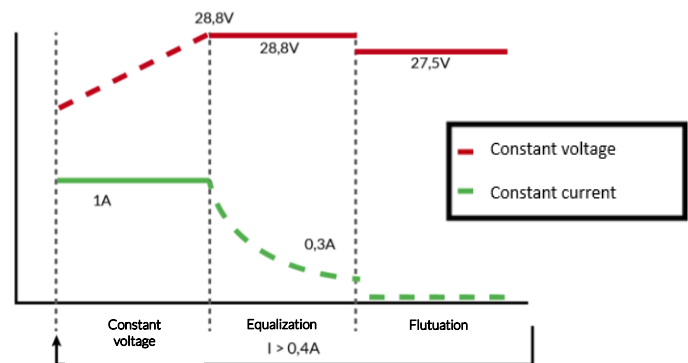

The graph above shows the charging stages of the battery charger, illustrating the behavior of the voltage and current of the batteries as well as the migration point from one stage to the next. Current values might vary depending on the source model.

Note: Graph for a charger configured for a load current 1A.

# FUNCTIONAL DIAGRAM

FUNCTIONAL DIAGRAM FOR MODELS 12V/20A, 24V/10A, 24V/15A

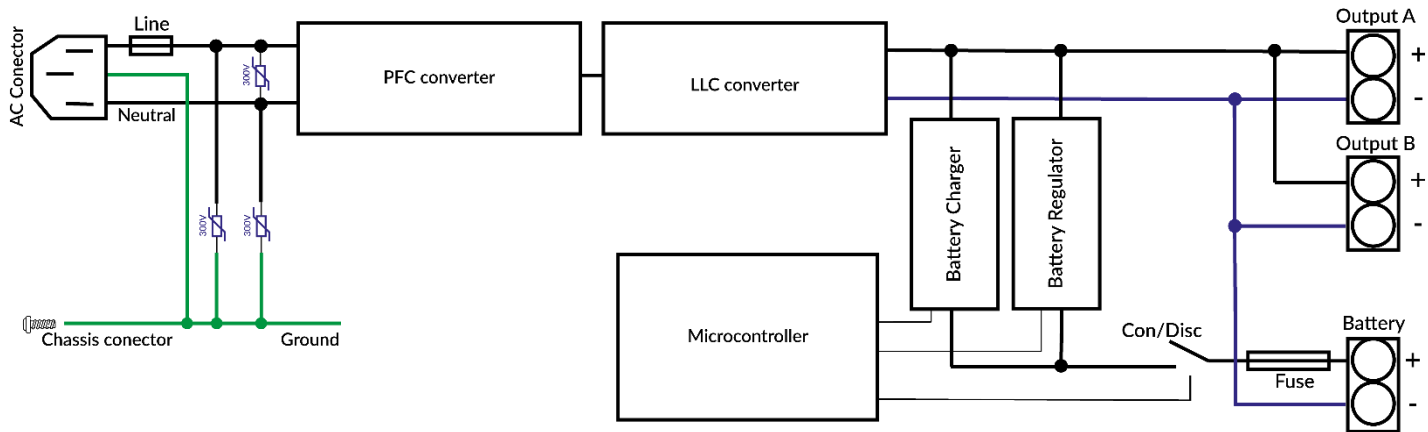

FUNCTIONAL DIAGRAM FOR MODELS -48V/5A AND -48V/10A

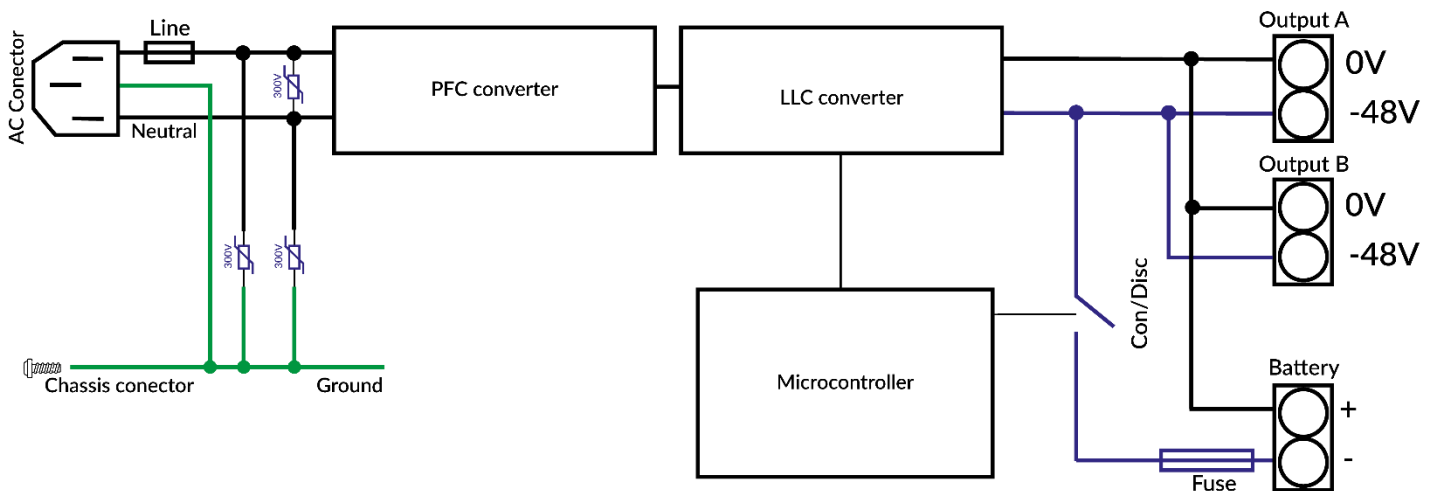

# MICROCONTROLLABLE SMART

The DC UPS features a microprocessor that runs the battery-charging algorithm, battery under voltage protection, Nobreak operation mode, time control for AC power return. All these functions are done with the mathematical calculations and precision of a digital control developed to deliver the most stable voltage at the output. Fast protections such as short circuit, input power loss, transient AC to battery, short circuit with battery connected, over temperature, are performed by fast analog circuits designed to protect the DC UPS, the user and the load connected to it. We put together the best of digital with the best of analog.

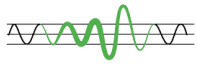

**Outbreaks:** protects the DC UPS against lightning or various atmospheric discharge.

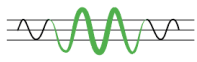

**Overvoltage:** protects against the effects of electrical distribution network maneuver.



**Falls:** protects against the effect that happens in installations when the distribution grid receives high load.

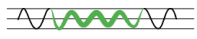

**Under voltage:** prevents a drop in the level of the electrical signal, a problem usually caused by the imbalance in the distribution of electric energy.



**Noise:** prevents that the interference in the electrical network caused by electromagnetic emission or by radio frequency transmissions interferes with the DC UPS output.



**Electrical faults:** caused by faults in the power supply.

The output voltage varies depending on the model of the source and the mode of operation. Please see table below.

Model	Nobreak Mode Output Voltage		Output voltage AC mode
12V 20A	$V_{BAT} > 12V = 12V$	$V_{BAT} < 12V = V_{BAT}$	12V
24V 15A   24V 10A	$V_{BAT} > 24V = 24V$	$V_{BAT} < 24V = V_{BAT}$	24V
-48V 10A   -48V 5A	42V a 58V according to the state of the battery bank.		

## REGULATORY COMPLIANCE

### ELECTROMAGNETIC IMMUNITY

Electrostatic discharge (ESD)	IEC 61000-4-2	Contact discharge Discharge through the air	8kV 15kV	Criterion C*
Fast transients (Burst)	IEC 61000-4-4	Power input Source output	4kV 1kV	Criterion A*
Outlet voltage surge (Surge)	IEC 61000-4-5	Phase-> Neutral Phase-> GND; Neutral-> GND	4kV 4kV	Criterion A*
Output voltage surge (Surge)	IEC 61000-4-5	+ -> - + -> GND; - -> GND	1kV 1kV	Criterion A*
Voltage dip (Dips)	IEC 61000-4-11	0% - 100Vac 40% - 100Vac 70% - 100Vac 0% - 220Vac 40% - 220Vac 70% - 220Vac	0Vac,20ms 40Vac,200ms 70Vac,500ms 0Vac,20ms 88Vac,200ms 154Vac,500ms	Criterion A*
Voltage interruption	IEC 6100-4-11	0% - 220Vac	5000ms	Criterion C*

\***Criterion A:** Power supply has normal behavior with the output at its set value.

\***Criterion C:** Temporary loss of function is possible. The power supply may shut down and return to normal operation.

The table below shows the power for equipment according to the charger configuration.

Model	Total output power	Maximum Charger			Minimum Charger		
		Equipment power	Equipment output current	Charger current	Equipment power	Equipment output current	Charger current
12V 20A	240W	120W	10A	10A	228W	19A	1A
24V 10A	240W	120W	5A	5A	216W	9A	1A
24V 15A	360W	120W	5A	10A	336W	14A	1A
-48V 5A	270W	108W	2A	3A	216W	4A	1A
-48V 10A	540W	270W	5A	5A	486W	9A	1A

#### ELECTRICAL SAFETY

Entrance/Exit	SELV	IEC 60950-1 Double isolation on reinforced isolation
Protection class	I	Needs ground connection
Leakage current	Typical <0,1mA/0,2mA Typical <0,4mA/1,0mA	100Vac,60hz 264Vac,60hz

#### DIELECTRIC STRENGTH

Phase+Neutral for output	3000 Vac	During 60s
Phase+Neutral for ground	2500 Vac	
Exit to ground	1000 Vac	

#### ISOLATION

Phase+Neutral for output	>5 Mohm	500 vcc test
Phase+Neutral for ground		
Exit to ground		

## DIMENSIONS AND WEIGHT

Height	45 mm
Width	186 mm
Depth	230 mm
Weight	1.94 kg

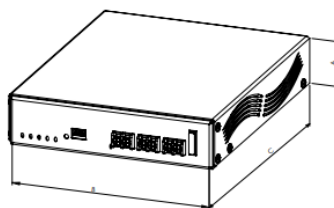

## FREE DISTANCE FOR VENTILATION

a	30 mm
b	30 mm

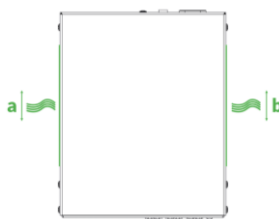

## PACKING

Material	Cardboard
Height (A)	71 mm
Width (L)	215 mm
Depth (P)	334 mm
Weight	2,6 kg

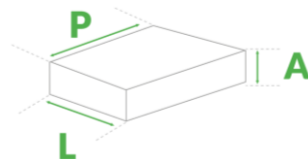

# ATTENTION TO GUARANTEE!



*Installation and maintenance* should be performed by trained and authorized personnel to minimize hazards to oneself and others.



It is installer's responsibility to **comply with regulations** applied to the installation, as well as follow the instructions of this guide.



Use only **components and fixing elements provided by ALGcom**.



Perform at least one **annual installation inspection** to verify the equipment conditions.



## DO YOU USE A BATTERY BANK?

Use the ALGcom outdoor enclosures with space reserved for batteries.



+55 54 3201.1903 | [algcom@algcom.com.br](mailto:algcom@algcom.com.br)  
Caxias do Sul - RS | Brazil | [www.algcom.com.br](http://www.algcom.com.br)

